

Ducta-Bright 7a Nickel™ - An Advanced Nickel Plating Engineered Specifically for Critical Ammunition Components

The advantages of nickel plating of ammunition components has been utilized by the ammunition industry for many years. Nickel plating of brass casings offers marked improvements over brass alone, including:

- Improved feeding in all actions of firearms
- Enhanced corrosion resistance and reliability during extended storage or field exposure
- Improved visibility for low-light chamber checks
- Improved cosmetics and ease of cleanup during reloading

Very early on in ammunition development, the corrosion resistance of nickel was found beneficial on revolver calibers to avoid tarnishing of brass casings which came into contact with leather belt pouches and holsters used by law enforcement. More recently, the advantages of nickel have found greater use within the ammunition industry for critical defense, carry, and law enforcement applications as well as for premium safari-grade hunting calibers.



However, complications with nickel plating often caused ammunition engineers to hesitate from specifying nickel for new applications. Historic issues such as cracking or flaking of the nickel deposit, as well as a reduction in the reloading capacity - the overall number of reloading cycles that a casing could endure - were common and often detracted from the marked benefits that nickel offers.

Ducta-bright 7a Nickel™ - Engineered Ductility, Guaranteed Function

The engineering group at Advanced Plating Technologies recognized the limitations of traditional bright nickel and set forth to develop a bright nickel system that eliminated the performance deficiencies of traditional bright nickel plating. A year-long engineering study ensued in which over thirty distinct bath solutions, brightener systems and operational parameters were investigated. The performance of each lot was tested both in controlled lab impact testing as well as live firing and reloading evaluations.

After all testing had concluded, it was found that Lot 7, Group A produced results superior to any other combination of variables and process application. The resulting Ducta-bright 7a Nickel™ process not only yielded a fully lustrous as-plated deposit but significantly reduced the as-plated stress that limits the performance of traditional bright nickel systems. Ducta-bright 7a Nickel™ produces a deposit with nearly five times the ductility of traditional bright nickel systems and nearly 85% the ductility of an unbrightened nickel deposit.

Ducta-bright 7a Nickel™ is the only nickel system available today that has been engineered to withstand the bi-directional and dynamic impact stress loadings that ammunition components must endure. Simply put, there is no other bright nickel system today that can provide the durability, reliable function and reloading capacity of Ducta-bright 7a Nickel™. Ducta-bright 7a Nickel™ is the benchmark plating process provided by Advanced Plating Technologies and is the foundational process for APT's premium coating offerings including Techni-Crom® and Black-TPD™ processes.

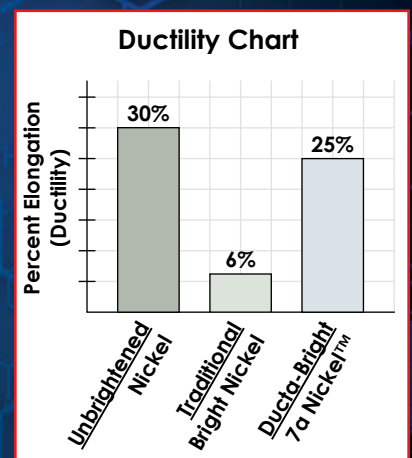

Traditional Bright Nickel - A Performance Gap When Used for Ammunition Applications

Nickel electrodeposits can be plated in both the brightened and unbrightened (matte) condition. Bright nickel plating has been the historic nickel deposit of choice within the ammunition industry due to the improved luster and point-of-purchase appeal that a bright deposit imparts. However, many of the functional issues with traditional bright nickel plating - such as cracking and flaking of the deposit - are inherent in the mechanical property limitations of a bright nickel deposit.

In order to electroplate nickel with a bright appearance, organic brighteners must be added to the nickel plating chemistry. Organic brighteners refine the nickel deposit to produce a lustrous finish. However, the brighteners also have the undesired effect of co-depositing within the nickel deposit. These co-deposited organics increase the as-deposited stress of the nickel and reduce the percent elongation (ductility) of brightened nickel deposits to less than one-fifth of an unbrightened nickel deposit.

The reduction in ductility of traditional bright nickel deposits can produce a performance-gap with the design requirements of modern ammunition. Components such as shell casings and primer cups must endure repeated cycles of compressive and tensile stress during the manufacture and reloading of ammunition. During loading, casings are sized or flared, which imparts tensile stress in the deposit. Seating of a projectile imparts further tensile stress as the casing expands to the outside diameter of the projectile. The casing is then taper or roll crimped which reverses the stress in the compressive direction. The nickel coating must withstand this bi-directional loading stress followed by the violent dynamic impact stresses that occur during firing. This stress cycle is then repeated numerous times if a casing is used for reloading.

What are Organic Nickel Brighteners?

The process of electroplating of nickel was originally developed by Oliver Patterson Watts in 1915. Originally, nickel was only plated from an unbrightened condition and had to be mechanically buffed or burnished to achieve a lustrous finish. Due to the costs associated with post-plate polishing, considerable research and development was performed on methods to plate nickel in the as-bright condition. It was found that brightness can be induced in a nickel finish with organic aliphatic and aromatic compounds that decompose at the surface of the deposit to refine the grain size. However, these compounds also co-deposit sulfur and carbon in the nickel, increasing the as-plated stress of the deposit. The increased as-plated stress reduces the plating's ductility and corrosion resistance, limiting the deposit's capacity to flex.

Shell Casing Loading

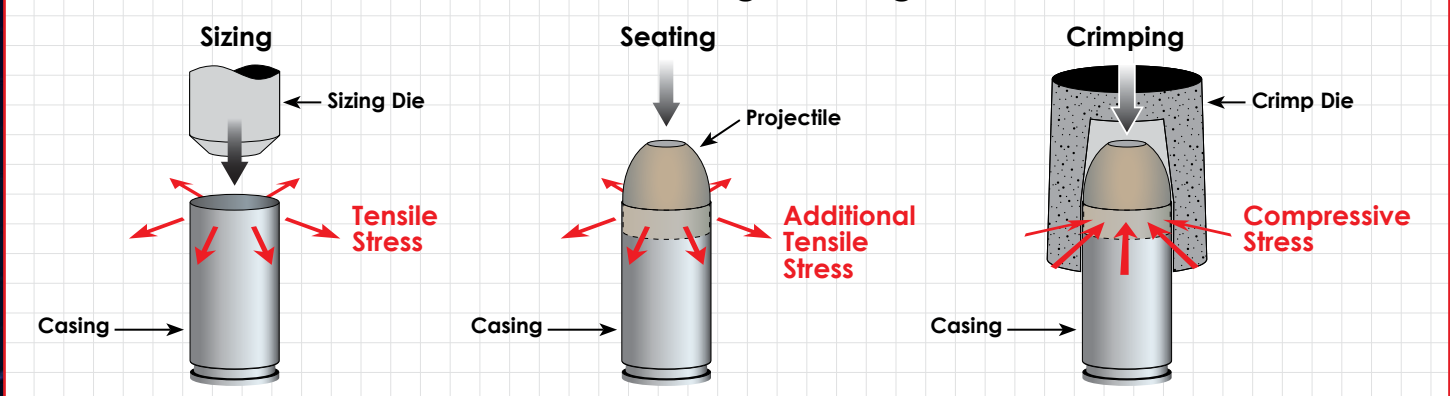

Learn More About Ducta-bright 7a Nickel™

Visit Advanced Plating Technologies online at: www.AdvancedPlatingTech.com

More information can be found about Duct-bright 7a Nickel™ in the "Solutions in Surface Finishing" menu.

Contact a member of our technical sales team at: sales@advancedplatingtech.com



405 W CHERRY STREET
MILWAUKEE, WI 53212-4095

PHONE [414] 271-8138
OFFICE FAX [414] 271-4972
SALES FAX [414] 271-5541

WWW.ADVANCEDPLATINGTECH.COM